

## No Hoods? No Vents? No Problem!

*From bacon and eggs to burgers and steaks, increase your profits and customer satisfaction!*



**Ventless Operation** – VentaGrill is equipped with a self-contained UL Listed Type I Hood design. This includes a four-stage filtration process, forcing grease laden air through a stainless steel baffle filter, a fire-rated pre-filter, a High-Efficiency Particulate Air (HEPA) filter, and finally through a High-Carbon-Charcoal filter to catch even the smallest of particulates. This advanced hood system surpasses the EPA-202 Test for clean air standards.



**Dual Temperature Control** – Each side of the griddle has its own thermostat control to allow for high capacity when you need it, and energy saving efficiency when you don't.



**ANSUL Fire Suppression** – Each VentaGrill has its own built in ANSUL® R-102 Fire Suppression System to ensure safety for your business.



**Integrated Ventilation Safety System** – To ensure proper operation, VentaGrill will not heat up if its filters are not in place. Additionally, VentaGrill will monitor airflow through its ventilation system optimizing performance and notifying the operator when filter replacement will soon be necessary.



**Reliable Construction** - VentaGrill is proudly manufactured in Northborough, MA. Backed by the same service and support Motion Technology, Inc. is known for, VentaGrill is built to last.

# VentaGrill™ SPECIFICATIONS

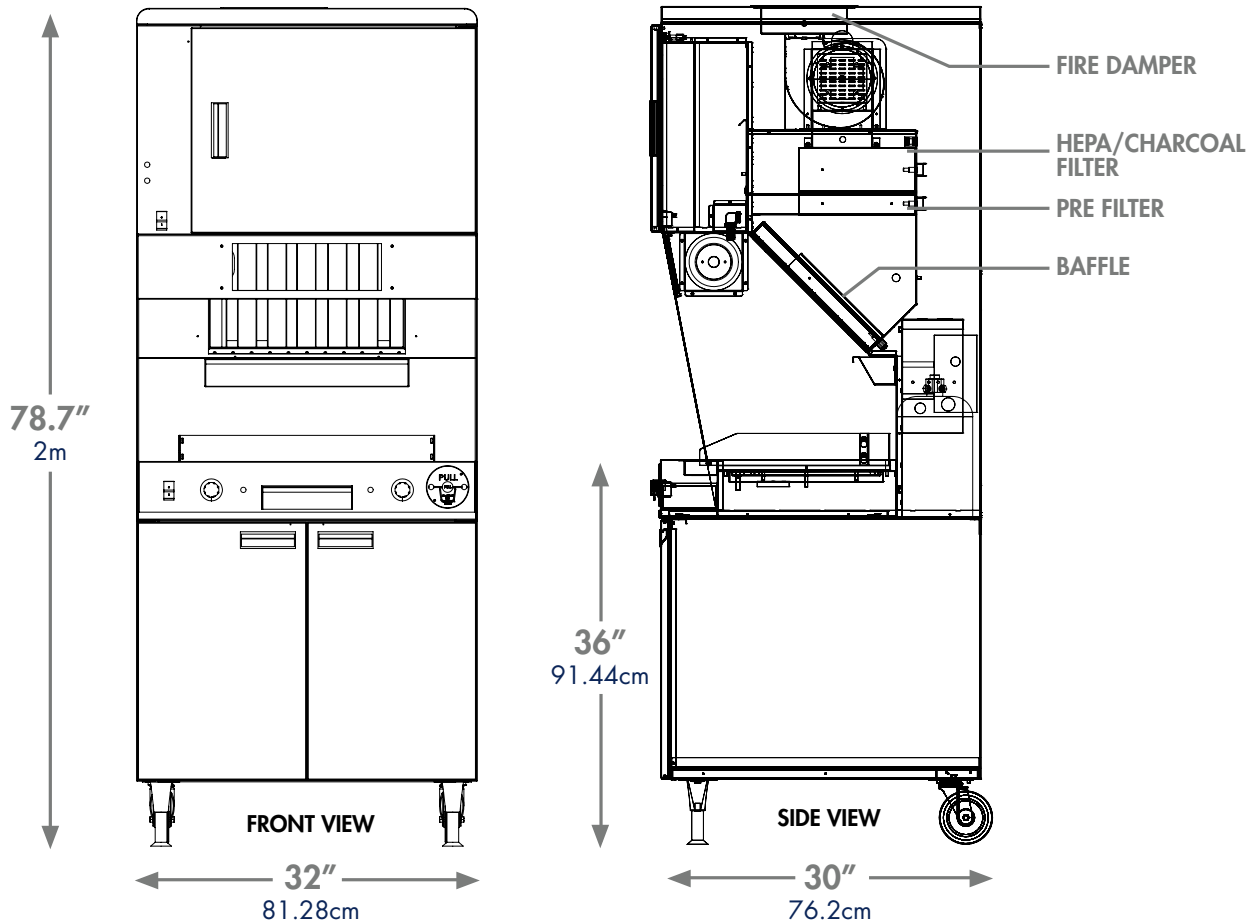

## ELECTRICAL

### SINGLE PHASE



208-240 V / Single Phase / 8kW Total  
40 AMP @ 240 V  
6' (1.83m) Power Cord w/6-50 Plug

### THREE PHASE



208-240 V / 3 Phase / 9 kW Total  
30 AMP @ 240 V  
6' (1.83m) Power Cord w/NEMA Plug / 15-50P Plug

## GRIDDLE

Griddle Dimensions	23.75" W x 16.25" D (60.33cm W x 41.28cm D)
Griddle Area	385.94 in <sup>2</sup> (.25 m <sup>2</sup> )
Temperature Range	200° - 400°F (93.33° - 204.44°C)

## MACHINE

Dimensions	32" W x 30" D x 78.7"H (81.28cm W x 76.2cm D x 2m H)
Weight	460 lbs (208.65 kg)
Construction	16 Gauge Stainless Steel
Shipping Dims.	38" W x 36" D x 86" H (96.52cm W x 91.44m x 2.18m H)
Shipping Weight	560 lbs. (254.01kg)

## WARRANTY

Limited one (1) year parts and labor

APPROVALS PENDING

We reserve the right to change specifications appearing upon this brochure without notice and without incurring any obligation for the equipment.



Your Source for Ventless  
Kitchen Solutions



[www.VentaGrill.com](http://www.VentaGrill.com)  
[www.MTIproducts.com](http://www.MTIproducts.com)



P: 800-348-2976  
F: 508-393-5718



10 Forbes Road  
Northborough, MA 01532