



MultiChef XL DATA SHEET

No Hoods. No Vents. No Problem!

Take a look at the little fast bake oven delivering big results.



Rapid Bake Technology – MultiChef XL uses convection, rapid impinged air, bottom infrared, and precision microwave to reduce cook times. MultiChef XL transforms your business into a food preparation powerhouse and **cuts cook times by more than 80% with superior results.**



Ventless Operation – The MultiChef high speed oven is equipped with its own internal ventilation system so you'll save money as there is no need to install any costly vents or hoods to operate. Without needing to be located under a hood, MultiChef is also easy to relocate in the event of a remodel.



Ease of Use – MultiChef is extremely simple to use and clean, regardless of your kitchen knowledge level. With its **two step cooking system**, every menu item is just a few taps away! Plus with its **unique removable catalytic converter**, cleaning a high speed oven has never been easier.



Custom Menu – Your menu has never been so easy to execute. With USB port to upload and download recipes, you can easily create up to 80 presets for your menu items. Categorize recipes into groups, with up to six different steps, you can be sure each recipe outputs the perfect quality food for your customers.

MultiChef XL™ SPECIFICATIONS

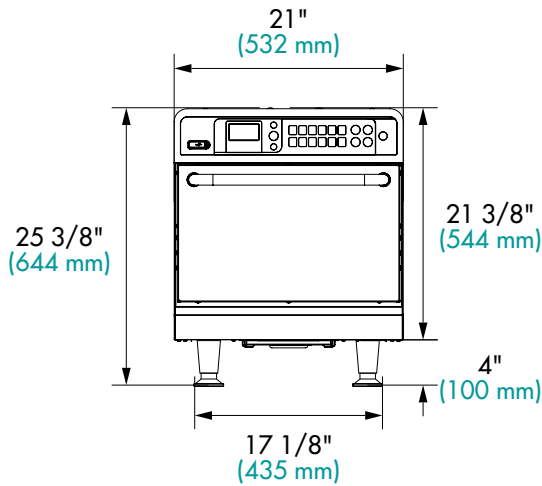

FRONT VIEW

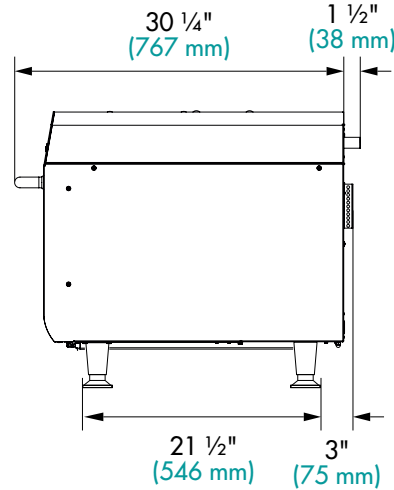

SIDE VIEW

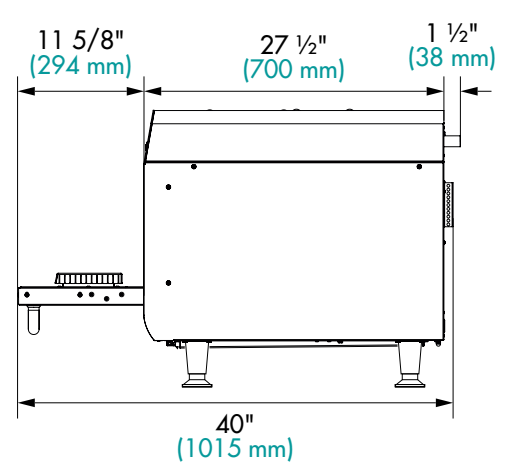

CAPACITY

External Dimensions	21" Wide x 31.75" Deep x 25.375" High (53.34cm Wide x 80.65cm Deep x 64.45cm High)
Internal Dimensions	15.5" Wide x 14.25" Deep x 5.75" High (39.4cm Wide x 36.2cm Deep x 14.6cm High)
Approximate Unit Weight	194 lbs. (88 kg)

ELECTRICAL

Voltage	208 / 240V
Frequency	60 Hz
Amperage	26.25 AMP @ 240 V
Maximum Input	6.3 kW
Plug Type	NEMA 6-30P (US) 
Cord Length	6' (1.83m) Cord
Cooking Temperature Range	86° - 536° F (30° - 280° C)
Clearances	0" Left Side, 0" Right Side, 3" Back (7.6 cm)

SHIPPING

Approximate Crated Weight	229 lbs. (103.87 kg)
Approximate Shipping Crate Size	38" Wide x 32" Deep x 36" High (96.5cm Wide x 81.28cm Deep x 91.44cm High)



WARRANTY

1 Year Parts/Labor, 3 Years Electronic Controls

NOTES

We reserve the right to change specifications appearing upon this brochure without notice and without incurring any obligation for the equipment.



Your Source for Ventless
Kitchen Solutions



www.MultiChef.com
www.MTIproducts.com



P: 800-348-2976
F: 508-393-5718



10 Forbes Road
Northborough, MA 01532